

Digital Seed: An interactive toy for children's explorations of plant growth and life cycles

Mauro Cherubini, Jamie Rasmussen

Everyday Learning, Media Lab Europe,
Sugar House Lane, off Thomas St., Bellevue, Dublin 8, Ireland
{mauroc, jrasmuss}@media.mit.edu

Hugh Gash, Tom McCloughlin

Psychology Department, Saint Patrick's College, Dublin City University
Drumcondra, Dublin 9, Ireland
{Hugh.Gash, Tom.McCloughlin}@spc.dcu.ie

Abstract. Preschool children, aged 4 and 5 years, report different understandings of the phenomenon of plant reproduction. We use their ideas as a starting point in designing an electronic device that illustrates phases of plant growth in response to children's augmentations or inhibitions of levels of water, light and temperature. Sensors are the crucial bridge between physical and virtual, as they detect physical actions and trigger virtual representations. The represented "digital seed" behaves much like a real seed, thus compressing the time required for phases of plant growth and providing a tool for children to experiment with relevant environmental conditions. We work with the children throughout the course of the project, in designing and refining the tool and in following conceptual changes as they occur through use of the device.

Keywords. Life sciences, children's thinking, conceptions of botany, Constructivism, micro-worlds, misconceptions of science, interactive toys, genetic epistemology, situated learning, handheld technology, sensors, play

1 Introduction

In this study, we consider how Constructivism could inform learning about an aspect of life sciences - the cyclic nature of plant growth. Our goal is not to conduct a psychological study of developmental stages or phases, but to provide an environment in which children can explore concepts and eventually to be in contact with their own conceptual growth. We do not want to force children to follow a specific path, nor to teach them a piece of pre-ordained ecology curriculum. Rather, we want to provide them with a playful way to experiment with plants and seeds in the world of plant growth. On the basis of children's conceptions, we designed and build a model of a plant's life cycle, which they then critiqued. Here we review our eliciting and representing of ideas related to germination, growth and pollination.

This is a qualitative pilot study combining results of clinical interviews with an iterative design process, to produce an interactive toy with physical and virtual components (see Hanna, Risdén & Alexander, 1997 and Van Setten, van der Veer & Brinkkemper, 1997). We regard the children's varying understandings of plants origins' and growth as being potentially reflective of good reasoning within their relatively constrained realms of experience, and inevitably useful in their learning processes (Smith, Di Sessa & Roschelle, 1993). Their imaginative responses inspired our representations and the interactive design.

2 Common conceptions among children

2.1 *Initial workshop*

We conducted the initial workshop in a primary school near Dublin with 15 preschool children, 4 and 5 years old, of varying gender and socio-economic status. Some of them have previous experience with gardening, though that does not ensure consistent or complete understandings of botanical processes. The materials included crayons, sheets of paper for drawings, a small box with soil, seeds of various kinds (green beans, maize, oats, apple, & tomatoes), fresh fruit (whole and cut apples (red and green), oranges, & tomatoes), plants, flowers, and pictures of vegetables, fruits, flowers, and trees (see Figure 1). Each interview included a child, an interviewer, a note-taker who intervened occasionally, and a tripod-mounted video camera that recorded each session. As in the classical Piagetian clinical interview², our prepared questions framed the enquiry but did not dictate a sequence for the conversation with the children (see Appendix A). We asked questions that seemed natural in response to each child's thinking. We designed our questions not to imply a yes/no answer or a particular avenue of response, but to reveal each child's unique reasoning. We tailored the questions during the course of the conversations, as we noticed ways particular terminology did or did not seem to address or reflect the children's thinking. We tried to be unobtrusive and not to suggest answers. The children expressed themselves by speaking, gesticulating, drawing pictures, and manipulating objects. We welcomed and encouraged each kind of answer. Our goal was to focus on the reasoning process behind the words and actions. Each of the child's communications contributes to our emergent interpretation of an overall consistency in the child's thinking.

We report here the most common children's conceptions we discovered in the initial workshop. The order of categories does not reflect any sequence of conversation. We have changed the children's names to protect their privacy. Most of the results find a synergic relation with Gelman and Hickling (1995) although we found reasoning on the causal mechanisms pertaining to growth to be less strong.



Figure 1. The workshop setting

2.2 *Origin of the seeds*

A seed's origin is not clear to children of this age range. We registered different conceptions of the origin of seeds: humans make them, they came from a seed box, seeds come from far away. Some children have more naturalistic

² See Introduction of Piaget, 1929, see Berg & Smith, 1985 and the three studies of Driver, Scott & Wood-Robinson, 1995 and 1996.

⁴ For the case of inheritance see Springer & Keil, 1989.

conceptions: seeds can be found in the soil, or in the plants but not in a specific location. None of the children interviewed seems to relate the seed with the fruit of the plant, even if the half-apple, with its seeds, is visible in front of them.

For example, Carl's first answer assumes a non-naturalistic source. *Carl (5)*: Where do you think the seeds come from? *From ... the apple shop*. What would happen if I was unable to find the seed in the apple shop. Where do I have to go? *I think I don't know, maybe from the apples*.

Patrick (4): Where do seeds come from? *From the seeds shop*. And if I was unable to find seeds in the shop where do I have to go? *Far away*. Where do I have to go? *In England*.

Mary (4): Where do you find seeds? *You can find them under the ground*. ... How does this seed get inside this apple? *Mans just put it in there*.

Sarah (5): Where do the seeds come from? *From the packages in the shops*. Can you find them anywhere else? *Sometimes you can find them in the tree*.

Gwyneth (4): Where do seeds come from? *Under the ground*. And where? *Where flowers are*.

Cara (4): What makes the seeds? *You put them in the muck*. And then? *You need a circle*. (She traces with her finger a circular movement on the table.)

2.3 *Origin of the plant*

Children tend to consider the seed and the plant as distinct objects. So the origin of the plant can be uncertain as well as the origin of the seed.

Carl (5): If I would like to grow another plant like this, what will I have to do. *You will have to put in a box*. What do I have to put in the box? *You have to put a tree*. Where do I find the tree? *You will find it to the apple tree*. How does it start? *When you have a car, you have to look around for the apple tree*. *When you find the tree, if it is a small tree, you can put it into a box*. (Carl offers no explanation of how this or any tree would have originated. Later, he develops an elaborate story about the moon and the sun talking to the plant, which becomes sad but does not sprout any seeds.)

Renny (5): Are these plants from the ground? *No*. Where are they from? *You can get flowers in the shops*.

2.4 *Growth of the plant/seed*

For most of the children, growth means just becoming bigger and bigger. They seem to lack a conception of progress through phases and a perception of qualitative differences in the morphology of the plant.

Carl (5): Let's imagine that the seed will grow. How will they grow? *They will grow bigger and bigger*. So they will keep growing bigger? *Yes*.

2.5 *Relation between seed and plant*

The relation between seeds and plants is not so clear for the children. Some of them think of seeds as food for the plant, implying that seeds help the plant to grow. However, these children do not associate seeds with the plant's origin.

Carl (5): If I were to take this seed out of the apple, what I would do with that. *You put to the apple tree*. So here is an apple tree, where do I have to go? (He points to the base of the plant) So I would have to put the seed on the apple. And then what would happen. *It will go up, up, up into there* (He points to the top of the tree). Would I get an apple from that? *Yes*.

Patrick (4): What would you do with the seed to make the plant grow? *Give it water*. Can the seed grow anywhere? *Under the plant*.

Mary (4): Would I be able to use a tomato seed to grow an apple tree? *No, you can use them to grow a tomato tree*. Do I have to put the seed inside? (The interviewer points to the soil in the potted plant.) *You make the tomato grow*. With what? *With the tomato tree, and them will grow on it*. How would I get a tomato tree? *You have to buy one*. ... Do plants need help to grow? *Yes, they do*. What do they need? *You need to put many seeds into the plant*.

Cara (4): How does this became a flower? What do you do with the seed? *You put them in the flowers* (She points to the flower). And what happens to the seed? *It grows up*. And what does it mean to grow up? *It needs the dark*. Where do you find seeds? *In the apples*. ... What do you need to grow? *My breakfast*. And, what does the plant need when it gets hungry? (pointing to the seed) *This*. The seeds? *Yes*. ... Do seeds have a mummy or daddy? *Yes*. (pointing to another seed) This is its mummy? *Yes*.

2.6 *Flowers and fruits*

None of the children seem to sense the sequence seed – plant – flower – fruit – seed. This is also related to the idea of progression between phases, stages or states.

Shannon (4): What is a seed? *A seed is ... you have to put it into the ground and then is a flower.*

Rose (4): What this seed will grow into? *A flower.*

2.7 Roots

Most of the children interviewed do not mention the presence of roots and their function for the life of the plant.

Sarah (5): Why do plants sit in the ground? *Because they have to, till they grow.* Then what happens? *Some apple will grow on the tree.*

2.8 Placement of the seed in order to grow

Most of the children who recognize the seed as responsible for the origin and/or nourishing the growth of the plant still are not clear about where to put the seed so that it will mature or increase in size. They think they should put the seed into the flower or that the seed grow under the plant, which does begin to suggest an idea of relation with the soil. In addition, they do seem to understand some need to access the plant as it grows.

Mary (4): Where do you have to put the seed to get it to grow? *Maybe around the plant in a circle.* How do you get the seeds to grow? *They need water.*

2.9 Species and relation with seeds

Most of them do not have a clear idea of the relation between a certain kind of plant and its seed. So for them it is possible to grow (whatever means “to grow” for them) an orange tree using an apple seed, an apple tree using a tomato seed, etc.⁴

Carl (5): If I was to plant this tomato seed, would I be able to get an apple? *Yes you could.*

Patrick (4): Would I be able to use an apple seed to make an orange. *Yes.*

Mary (4): Would I be able to use the apple seed to make a tomato tree? *Maybe because the seed colour is the same of the apple.*

2.10 Environmental conditions responsible for the growth

Children consider water to be an important factor in the growth of the plant. Most of them consider also the light (sunshine) as an important factor.⁵ Not one addresses invisible conditions for growth such as temperature and the presence of circulating air.

Patrick (4): What do plants like? *Water.* Do plants like anything else? *No.* Do you think plants like morning or nighttime? *Morning.* Why? *Because they like sun.*

Mary (4): Can a seed grow anywhere? *Yes, they grow wherever they have to grow.* Can a seed grow on this piece of paper? *Yes, it just needs water.* Can the seed grow in this pot? *Yes, it will grow longer.* Why? *Because I had plants before.*

Cara (4): Do you think that this plant likes the morning or the nighttime? *The nighttime.* Why? *Because makes some sleep.* What would happen if I put this plant in the dark all the time? *It gets dead.* Does this plant need light? *Yes.* Why? *It gets bigger.* So, what does it need, light or darkness? *Light.* ... What do these plants need to grow? *Water, they need to grow.* Do they grow by themselves? *Yes.* How come? (She puts the plant into the soil.)

2.11 Season, cycle and death

They do not anticipate a significant difference in the plant during the course of a year, but most of them do recognise the winter as the period in which the plant is sleeping. The children do not correlate progress in plant growth with the seasonal cycle. Plants, for them, seem to be “always” there with the same shape and size.

Patrick (4): Where do seeds come from? *From the seeds box.* Where do you find the seeds box? *Far away.*

Shannon (4): What does the plant look like during the wintertime? *They are dying.*

⁵ The light factor can also be related to other issues of conceptualization as explained in Driver, Guesne & Tiberghien, 1985.

2.12 Psychological, Human features

The children often talk about the plant anthropomorphically, for example as sad, happy or sore. They understand the difference between plants and humans in terms of what is missing: the plant does not have legs, so it cannot go to the bathroom; the plant does not have a mouth, so it cannot eat, the plant feels sore if it loses a leaf.

Patrick (4): Do you think this plant is alive? *No, because is not moving.* How do plants move? *They grow.* How do they grow? *They grow up.* ... Do plants feel hungry? *No.* How come? *Because they don't have a mouth.* How do they get food? *From the pot.* What is in the pot that feed them? *Nuts.* What do the nuts do. *Nuts make plants grow.* Do you see nuts on this table? *Yes* (He points to the seeds from the green bean pod.) ... Do plants breathe? *No, because they don't have a mouth.*

Sarah (5): Does a plant feel a touch? *Yes.* How come? *Because it just moved.* So if the plant moves it means that it felt that? *Yes.*

Renny (5): If I were to touch it, would the plant know? *No, because it doesn't have eyes.*

2.13 Being "alive"

We wanted to investigate the concept of being "alive" according to whether the plant possessed the following attributes: growth, reproduction, feeding, and breathing.⁶

Most of the children relate the concept of "being alive" with the idea of motion⁷. Therefore, a plant is not alive because it does not have legs or hands. Other children think that a plant is alive if its leaves point toward the sky and conversely, dead if the body of the plant points to the soil.

Mary (4): Do you think that this plant is alive? *Yes, because is going up.*

2.14 Time of growth

Carl (5): How long does it take the seed to grow up? *It takes 5 minutes.*

2.15 Food of the plant, metabolism

Most of the children are certain about the fact that plants drink water, but uncertain about whatever food plants may consume. Often this is identified with rocks among the soil or, sometimes, with water itself. None of the children considered soil as a source of nutrients.⁸

Carl (5): What tells you that the plant is breathing? *It is thinking that it is hungry.* How do you know that? *When it is hungry it has to eat these things.* What. *These things in there* (the little rocks in the soil).

Rose (4): What do plants need to grow? *Plants need plant food.*

Renny (5): What do they eat? *They eat and drink water.* ... What does this plant need to grow? *Seeds.*

2.16 Number of plants and number of seeds

Mary (4): How many plants can you get with 10 seeds? *You might have one. You have to get two seeds for each plant.*

Sarah (5): How can you make another plant? *Just putting two seeds.*

Shannon (4): If I were to plant watermelon seeds, what would I get from those? *A watermelon.* How many seeds do I need to use? *All of them.* To get how many watermelon? *One.*

3 The core concept of a cycle

This table summarizes commonly held views by comparing adults' and children's thinking. The table also provides a form for thinking through important relationships among the ideas. For each category, we asked the question of what concept/s would be needed in order to understand the idea. Discerning these relationships would help to articulate the conceptual structure of the domain, which would help in building the environment.

This is simply an initial foray into a complex analysis which we hope to pursue further, yet it suggests that the concept of cycle could be an important foundation for many of the other ideas. We do not consider this concept necessarily as a

⁶ The same approach was used in Stavy & Wax, 1989.

⁷ For this particular aspect see the study of Richards & Siegler, 1984.

⁸ See the summary of some researches in this topic in Bell, 1985.

precursor, as it seems that any of the related categories might lead to it just as it might lead to them. Nevertheless, the frequency with which the concept of cycle appears in this exercise reveals its importance.

CATEGORY	ADULTS' UNDERSTANDING	CHILDREN'S CONCEPTION	RELATION
1 Origin of the seeds	The seed is inside the fruit of the plant.	Seeds are made by humans or can be found in nature in a non-specified place.	CYCLE
2 Origin of the plant	A plant is born from a seed in the adequate environmental conditions.	A plant is always there.	RELATION WITH SEEDS
3 Growth of the plant	When the seed grows, it changes its properties and becomes the plant.	The plant does not grow, or it keeps becoming bigger and bigger.	CYCLE
4 Relation between seed and plant	The seed is the plant not yet born. It will become the plant in the right environmental conditions.	Seeds are food for the plant.	CYCLE
5 Flowers and fruits	Flowers and fruits are part of the chain between plant and seed.	Flowers, fruits and seeds are not related.	CYCLE
6 Roots	Roots are on the base of the plant, where the plant takes in nutrients.	[Roots are not conceptualized.]	FOOD OF THE PLANT METABOLISM
7 Placement of the seed in order to grow	The seed must be under the soil with the right humidity.	Under the plant or into the flowers, or into the plant.	ORIGIN OF THE PLANT
8 Species and relations with seeds	An apple seed can generate only an apple tree.	You can grow an apple tree from a tomato seed.	CYCLE
9 Environmental conditions responsible for the growth	There must be light, water, soil and the right temperature.	Water, sunshine.	CYCLE
10 Cycle	A plant will follow its own cycle from the seed to the mature plant to the newborn seed.	[Cycle is not conceptualized.]	[This seems to be the foundation concept.]
11 Psychological, Human features	A plant is a living thing without psychological features.	A plant can be sad, happy, sore, etc.	[This category seems to be singular.]
12 Being "alive"	A plant is alive because it is born, it grows and it can reproduce before dying.	Yes, because "it goes up", or no, because it "cannot move".	GROWTH OF THE PLANT
13 Time of growth	A plant grows in weeks/months.	It can grow in 5 minutes.	CYCLE
14 Food of the plant/metabolism	Water, minerals.	Just water.	ENVIRONMENTAL CONDITION
15 Number of plants and number of seeds	1:1	Many to one, one to many.	CYCLE

Table 1. Key ideas and relations

4 The toy design

4.1 Features

The Digital Seed (DS) is born from the idea that an interactive computational device could help children to play with the ideas listed above. We started from the problem of the time required for a real plant to grow. Obviously moving into a virtual world would be the easiest solution, but in this case we would have to renounce all the tangible features of a real plant and the subsequent richness of the learning environment that this would produce. Finally, we moved our design into a space between these two extremes. Without pretending to have all the features of a real plant, we selected the tangible aspects that we wanted to preserve in relation to the virtual world. We decided to maintain:

Water, a tangible element that children conceptualize as being responsible for the beginning of growth and for the maintenance of the health of the plant.

Temperature, an invisible condition for growth of the plant that the children did not address.

Light, corollary to the sunshine. This dimension is also very important for the growth of the plant and understood by most of the interviewed children.

A fundamental part of the learning environment is the interplay between these factors. In all the phases of the growth of the plant there is not just one factor that encourages growth, but it is the combination of necessary conditions. Humidity, temperature and light exposure are fundamentals for life: they have to be present at the same time and in the right proportions.

4.2 The physical interface

In the physical domain, we wanted a robust interface, with adequate dimensions, to support actions involving water, light, and changes in temperature, and which would be waterproof and shock resistant. We decided to use an iPAQ Pocket PC⁹, situated within a plastic cube with sensors and apparatus, as the elaboration unit and as the basis. Compaq's iPAQ is a PDA that is easy to use and yet powerful enough to do serious processing of sensor data (see Van Laerhoven, 2001). We used environmental sensors as a bridge between the real world and the virtual world to acquire quantitative differences in environmental conditions around the iPAQ. This acquisition process occurs through an interface board with a PIC microcontroller and a multiplexer. Essentially the PIC reads the sensors through the multiplexer and sends back the readings to the Pocket PC using the ASCII format over the serial line. We have 5 pairs of light and temperature sensors, one for each face of the cube excluding the base. We decided to use a flow sensor instead of a humidity sensor because we need to appreciate differential readings, not just an absolute value, and even more importantly because the commercial humidity sensors cannot be used in direct contact with water. Thus, the flow sensor allows children to pour liquid directly into the cube, thereby "watering" the virtual seed. We also incorporated a clap sensor and an accelerometer for further interactions (see Figure 2).

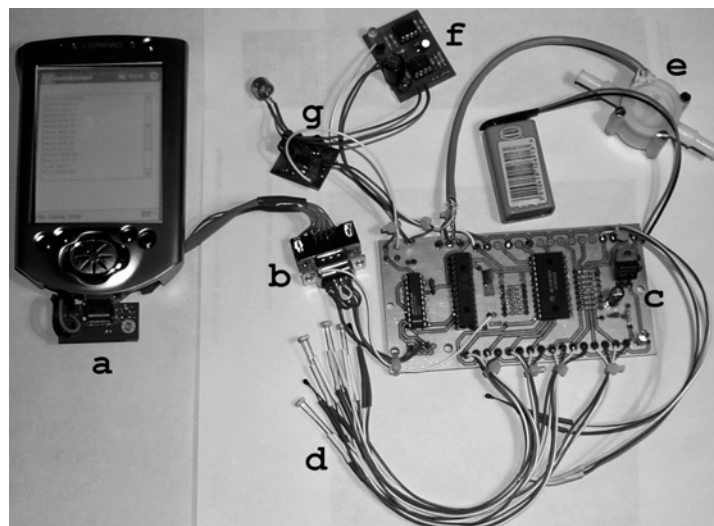

Figure 2. Sensors interfacing with the iPAQ. (a) iPAQ Pocket PC, (b) serial connection with the board, (c) interfacing board, (d) temperature and light sensors, (e) flow sensor, (f) clap sensor, (g) accelerometer

⁹ iPAQ is a trademark of Compaq Computers. For more information visit: <http://www.compaq.com>.

We packaged this equipment inside a cubic ABS box. We used two funnels, one on the top of the box, the other on the bottom, to focus the water flow through the flow sensor. An opening around the screen allows illustration of the story of the seed. Temperature sensors and light sensors are positioned on each face of the cube, enabling detections of changes in the direction of the light and the location of the principal heat source (see Figure 3).

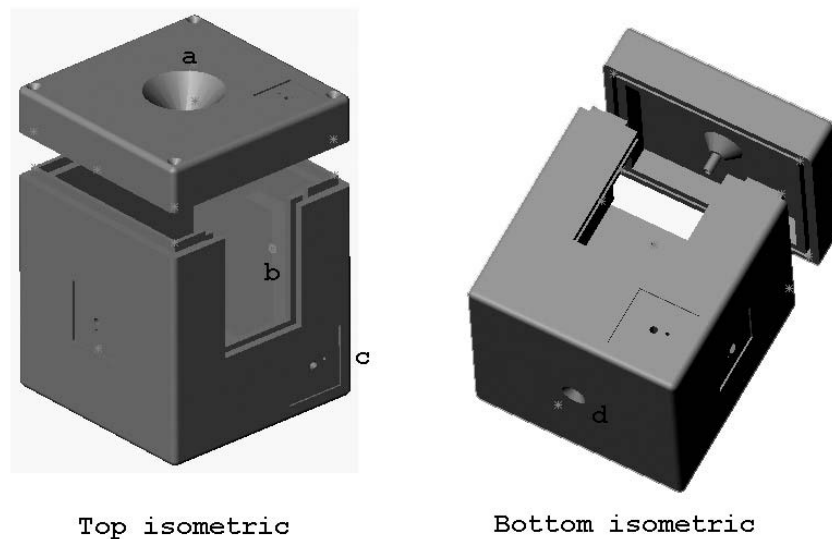

Figure 3. Representation of the external interface. (a) Funnel for water drainage, (b) Window for the iPAQ display, (c) holes for light and temperature sensors, (d) Small funnel for the exit of the water

4.3 *The virtual interface*

The software interface of the Digital Seed displays the story of an apple seed as a sequence of still illustrations, which play as a slow animation. Each image in the sequence is a bitmap; a transparent background allows the sprites to be placed in layers. The story of the seed begins before germination. In order to grow, the seed needs particular quantities of light, water, and temperature, dispensed at an even rate. Children can experiment with the sensors in order to generate favourable or unfavourable “environmental conditions”. If the plant receives too little or too much of any stimulus it will become visibly unhealthy. To encourage experimentation, the plant is robust enough to withstand most mistreatment and only dies after extreme abuse.

The software interface of the Digital Seed implements a Finite State Machine, or FSM. The FSM is a more concrete instantiation of the state map shown in Figure 4, including animations based on sensor input or plant state, such as clouds and rain or a pollinating bee. The program was written in Microsoft eMbedded Visual Basic 3.0 using the Pocket PC 2002 SDK.¹⁰

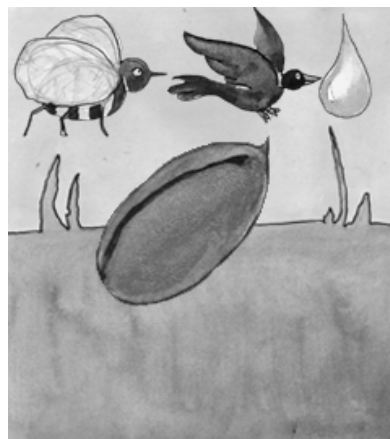

Figure 4. The software interface layout.

¹⁰ See Pocket PC 2002 Software Developers Kit: <http://www.microsoft.com/mobile/developer/>.

We take the liberty of exaggerating dimensions within the virtual world, in order to show each stage of growth optimally and to use advantageously the elasticity inherent in virtual representations (see Figure 7). For example, at the end of the cycle we zoom in on the fruit and then on its internal seeds.

Among the representations are a sun that follows the main source of light around the box, a bee that pollinates the flower, and a bird that tries to eat the apple but can be scared away by loud noises.

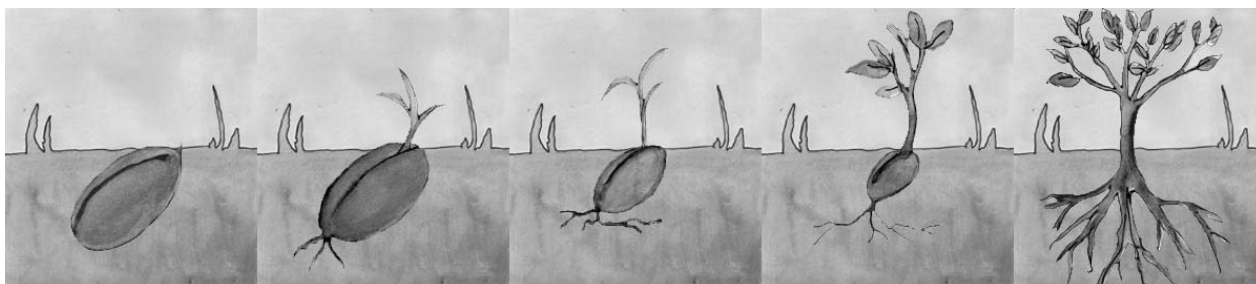

Figure 7. Some frames of the sequence of the growth in the healthy state.

5.2 *Key ideas interactions into the design*

The primary focus of this design is to illustrate continuity between the stages empathising the cycle that joins them: a plant is born from a seed, produces a seed that can give life to another plant, and so on. Flowers, fruits and seeds are all part of this cycle, part of the reproduction of the plant. The roots of the plants initially were hidden under the soil, but after the first workshop, we decided to show them as if the child was watching a cross section of the terrain in which the plant is living. First, we put the seed under the soil to illustrate the placement of the seed within appropriate environmental conditions for the growth. The design also, addresses species' relationships by maintaining the continuity between seeds and plants of the same kind. Controlling environmental conditions are fundamental to the interaction design.

6 **Interactions with the Toy**

6.1 *Follow-up workshop*

We worked with children interacting with the Digital Seed in a setting and manner similar to the first workshop, though this time the objects included a plant, the DS, some crayons, the toy, a mug of water and a flashlight. While there are shortcomings with the DS in its present form, we feel the children's reactions provide important feedback for the next phase of our work.

6.2 *Interaction with the toy*

Interactions with the toy revealed that the proportions of the illustrated seed from picture to picture (e.g., figure 8) were affecting children's understandings of the depicted situation. Also the children did not understand our representation of the camera effect of zooming in on a particular part of a scene.

The illustrated events are represented with just a few frames, which produce a crude animation without "dissolves" between stages of plant growth. While it was clear that the children enjoyed the animation, it did not always clearly represent the changes as the plant transformed from one stage to the next. At the end, for example, some of the children thought that the tree had simple "disappeared" and that a seed had appeared in its place.

The first sequence was particularly interesting because the children seemed surprised by the transition from seed to plant. This picture shows the seed germinating a sprout, something they likely would not have imagined. They seem to maintain a distinct separation between the seed and the plant. Also the design of the section of the terrain seems not to help the children to conceptualize the presence and function of the roots. Some of them refer to the roots as "sticks" or "leaves" that grow under the soil.

The design of the pictures is an important issue that emerged vividly from the follow-up workshop. In fact, sometimes the meaning of the pictures seemed to be uncertain. For example, we used a brown colour to express the "unhealthy" state of the wilted flower. Some of the children did not recognize this meaning.

This prototype is large, heavy and fragile, so the children tended to shy away from it just as they were drawn to the pictures. This inhibited direct manipulation of the box, the water and the lamp.

The mechanism designed to save the apple from the bird was hand clapping, though the interface does not suggest this and the children did not guess it. In fact, they did not interpret the bird as a threat.

A final point is that we think that the starting point with the DS should be the child's starting point, the plant, as the children more often had problems in relating the seed to the plant than the plant to the seed.

6.3 *Flow of states in the software*

The software design prescribes discrete cause and effect relationships between each picture and the next. Because it anticipates a single sequence of events, interactions are limited.

7 **Conclusions**

We regard children's ideas not as being systematised in stages, but as differing and changing over time and culture¹¹. We are not looking for an absolute truth, but we are trying to build an environment in which children can experiment with their ideas, an environment in which it would be possible to perform operations among many states and particular objects. This interplay is informed and inspired by love for a specific idea or domain; for example, the concept of life-cycle in this study. We think of knowledge as experience, and experiencing as defining one's own boundaries and curriculum (see also Peacock, 2000).

The work reported here only begins to suggest the richness of interactivity that we are striving for. Our next designs will support an indefinite number of computational states, perhaps using a simulation paradigm, and will display carefully coordinated representations in the interface, including images, sounds and tangible input devices.

The Digital Seed project is part of the Everyday Learning style at Media Lab Europe, where we are trying to appreciate and accentuate learning processes that happen in ordinary life, in daily tasks, in things that we learn because we choose to and in personal ways of developing knowledge. In this domain we believe that "to learn is to experience and to create".

8 **Acknowledgments**

We would like to thank several colleagues at Media Lab Europe: Carol Strohecker for thinking through the ideas and the writing; Brendan Donovan, for the PIC programming; Matthew Karau and Brian McDonald, for help in designing the electronic board; Mike Ananny, for the theoretical advice; James Condron and Steven Hughes, for help in debugging the electronic board; Valentina Nisi, for the art work; and Herve Gomez, for the important discussions about the workshop design. Also we would like to thank Anna Lometti, St. Patrick's College and California State University, Chico, for help in the workshop assessment, and Bakhtiar Mikhak, MIT Media Lab, for the important advice on the iPAQ-sensors interfacing. We thank the children for sharing their ideas with us.

9 **References**

9.1 *Children's early conceptualization of plant growth*

- Beverley, Bell (1985). Students' ideas about plant nutrition: what are they? *Journal of Biological Education*, 19 (3), 213-218.
- Hickling, Anne K., Gelman, Susan A. (1995). How Does Your Garden Grow? Early Conceptualization of Seeds and Their Place in the Plant Growth Cycle. *Child Development*, 66, 856-876.
- Leach, John, Driver, Rosalind, Scott, Philip, Wood-Robinson, Colin (1995). Children's ideas about ecology 1: theoretical background, design and methodology. *International Journal of Science Education*, 17(6), 721-732.
- Leach, John, Driver, Rosalind, Scott, Philip, Wood-Robinson, Colin (1996). Children's ideas about ecology 2: ideas found in children aged 5-16 about the cycling of matter. *International Journal of Science Education*, 18(1), 19-34.
- Leach, John, Driver, Rosalind, Scott, Philip, Wood-Robinson, Colin (1996). Children's ideas about ecology 3: ideas found in children aged 5-16 about the interdependency of organisms. *International Journal of Science Education*, 18(2), 129-141.
- Piaget, Jean (1929). *The child's conception of the world*. London, Routledge and Kegan Paul.
- Richards, D. D., Siegler, R. S. (1984). The effects of task requirements on children's abilities to make life judgments. *Child Development*, 55, 1687-1696.
- Richards, D. D., Siegler, R. S. (1986). The Children's understanding of the attributes of life. *Journal of Experimental Child Psychology*, 42, 1-22.

¹¹ This point is in relation with the study of Springer & Keil, 1991.

Springer, K., Keil, F. C. (1989). On the development of biologically specific beliefs: The case of inheritance. *Child Development*, 60, 637-648.

Springer, K., Keil, F. C. (1991). Early differentiation of causal mechanisms appropriate to biological and non-biological kinds. *Child Development*, 62, 767-781.

Stavy, Ruth, Wax, Naomi (1989). Children's Conceptions of Plants as Living Things. *Human Development*, 32, 88-94.

9.2 *Children's ideas in science. Related concepts*

Driver, Rosalind, Guesne, Edith, Tiberghien, Andrée (1985). *Children's Ideas in Science*, Philadelphia, Open University Press.

9.3 *Theoretical approach*

Berg, D.N., Smith, K.K. (1985). *Exploring Clinical Methods for Social Research*. Beverly Hills, CA, Sage Publications.

Peacock, Alan (2000). What Education do you Miss by Going to School? Children's 'Coming-to-Knowing' About Science and Their Environment. *Interchange*, 31(2 & 3), 197-210.

Smith, J. P., Di Sessa, Andrea A., & Roschelle, J. (1993). Misconceptions reconceived: A Constructivist analysis of knowledge in transition. *Journal of the Learning Sciences*, 3(2), 115-163.

9.4 *Interaction Design*

Hanna, Libby, Ridsen, Kirsten, Alexander, Kirsten (1997). Guidelines for usability testing with children. *Interactions*, 4(5).

Van Setten, Mark, van der Veer, Gerrit C., Brinkkemper, Sjaak (1997) *Comparing interaction design techniques*. Proceedings of the conference on Designing interactive systems : processes, practices, methods, and techniques, August.

9.5 *Sensors*

Van Laerhoven, Kristof (2001). *Augmenting the iPAQ with Sensor Boards via the Serial Port*. Retrieved April 11, 2002, from University Lancaster, UK, Faculty of Applied Sciences Web Site: <http://www.comp.lancs.ac.uk/~kristof/notes/>

10 **Internet site**

For further news and to access the full documentations of the project, visit the address: <http://www.mle.ie/DigitalSeed/> .

All the materials contained in the site are copyright Media Lab Europe. Reproduction or any other purposes may be authorised. Please write to the authors.

A Appendix. Guidelines questions for the initial workshop

Do you think this plant [HAVE A PICTURE / OR A REAL PLANT] is alive? ...

[IF YES:] how do you know? / Is it? How?

If I move the plant, does the plant know if I have, does the plant know it?

Can it move itself? How?

When I'm thirsty, how do I know? Do plants feel thirsty? How?

What happens if plants don't get enough water?

Does it like light? Why? Does it like more the morning or the evening?

Do plants feel hungry? Why? How?

What happens if plants don't get enough food?

What do plants eat?

Do plants go to the toilet? Why?

Do plants breathe? What do they breathe?

Do plants feel pain? If I pick a leaf, does it hurt the plant?

Can this plant grow? What's that like? What will happen?

What makes a plant happy? When is a plant happy? Sad?

How do plants know when to grow? How?

Did it grow because it wanted to?

Do plants need people to help them grow?

[IF YES - what about trees and grass and wild flowers - do they need people?]

Do you grow?

Do you have a dog, a cat? [IF NO SKIP TO NEXT QUESTION] Does it grow? Is it different from when a plant grows?

What is a seed?

Here's some seed [SHOW CHILD SOME SEED - ANY KIND] - how do you get them to grow?

Can a seed grow anywhere?

Tell me the story of a plant from when it begins as a seed. [ALSO CAN MAKE A DRAW]

Do plants have mummies and daddies?

Where do seeds come from? Where do you think I found these seeds?[SAY "I FOUND THEM IN MY GARDEN IN AUTUMN"]

This seed came from that plant [SHOW PICTURE OF ONE KIND OF PLANT]. What will the plant from this seed look like? [SHOW TWO MORE PICTURES OF DIFFERENT PLANTS WITH THE ONE ABOVE]

How did they get there [in my garden]? Why were they there in Autumn?

What would happen if I hadn't found them?/ if they stayed in my garden? Die or grow?

[SAY "LET'S IMAGINE THEY'D GROW"]

What happens then, once they've started to grow?

What does the plant look like in Spring? [DOES THE CHILD SUGGEST SOMETHING LIKE GERMINATION?]

What does the plant look like in Summer? [DOES THE CHILD SUGGEST THE PRESENCE OF FLOWERS AT THIS POINT?]

What does the plant look like in Autumn? [DOES THE CHILD SUGGEST SEED PRODUCED AT THIS POINT?]

What does the plant look like in Winter? [DOES THE CHILD SUGGEST SOMETHING LIKE HIBERNATION IN ANIMALS?]

If I got seed out of an apple [CUT APPLE IN HALF AND TAKE OUT PIPS] - and I planted/sowed them, what would happen? Would I get an apple tree?

If I got seed out of a tomato [CUT TOMATO IN HALF AND TAKE OUT SEEDS] - and I planted/sowed them, what would happen? Would I get a Apple tree? Cabbage? Orange tree? Carrot? Lemon tree? Tomato plant?

Is there a way to get an apple tree from a tomato seed?

Where can I found some seeds? Where do you find them?

What makes the seeds?

Why do plants sit in the ground? Do they go into the ground?

What happens if plants are pulled up out of the ground? [WHY DO YOU THINK THIS IS SO?]